

SECTION A-A  
SCALE 3

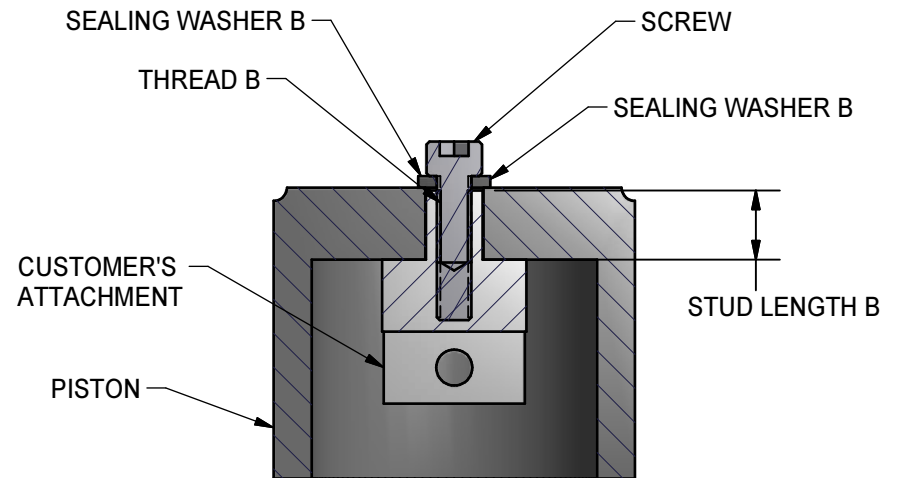

SECTION B-B  
SCALE 3

DIMENSIONS FOR PISTON MOUNTING STYLES A AND B

DIMENSION	MODEL 2K56	MODEL 2KS95	MODEL 2K160	MODEL 2K240	MODEL 2K325	MODEL 2K444
PISTON HOLE ID	.062	.101	.101	.101	.193	.193
THREAD A	#0	#3	#3	#3	#10	#10
STUD LENGTH A	.250	.250	.250	.250	.437	.500
SEALING WASHER A OD	.125	.188	.188	.188	.250	.250
SEALING WASHER A ID	.062	.101	.101	.101	.193	.193
THREAD B	N/A	#0	#0	#0	#6	#6
STUD LENGTH B	N/A	.120	.120	.120	.307	.370
SEALING WASHER B OD	N/A	.125	.125	.125	.250	.250
SEALING WASHER B ID	N/A	.062	.062	.062	.150	.150

**Airpot**<sup>®</sup>

35 LOIS ST  
NORWALK CT 06851  
US

203-846-2021  
www.airpot.com

DRAWING NAME PISTON ATTACHMENTS					DATE 10/16/2008	
THE TOLERANCES BELOW APPLY UNLESS OTHERWISE SPECIFIED					UNITS IN INCHES	
.XX	.XXX	ANGULAR	S. FINISH	CONCENTRICITY	SCALE 3:1	INITIALS KJL
MATERIAL NA				DRAWING NUMBER NA		REV A